

TECHNOLOGICAL REQUIREMENTS – HOT DIP GALVANIZATION

The modular design

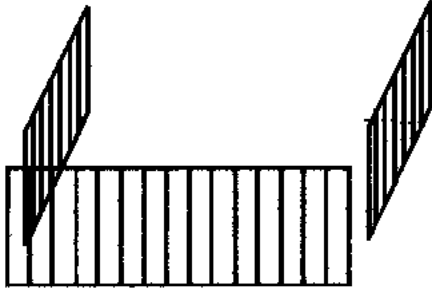

Right

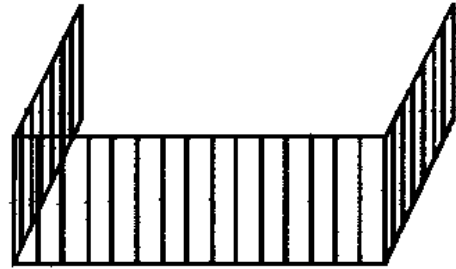

Wrong

The need of designing technological holes

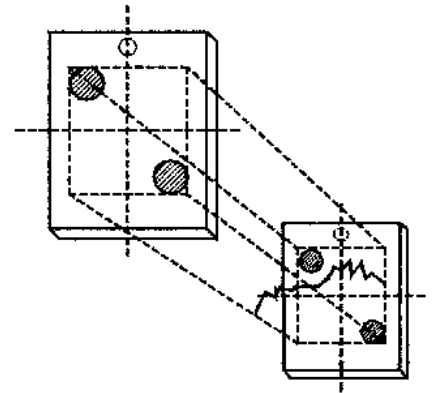
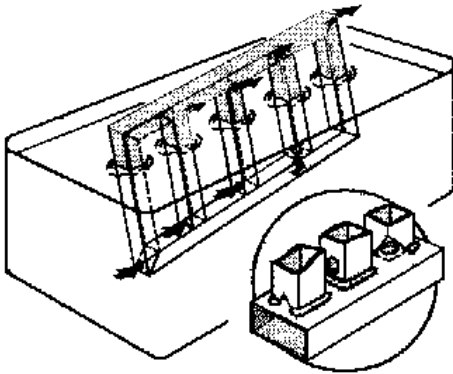

Corner rounding at the welded constructions

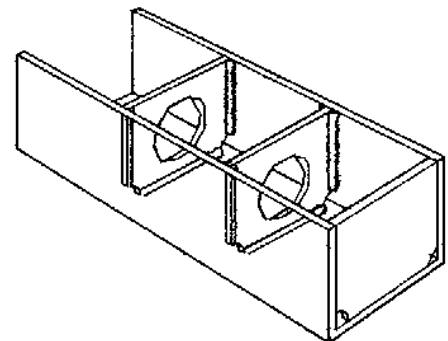
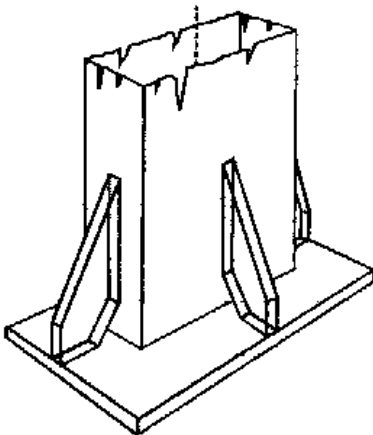

The correct execution and positioning of the joints at the tanks

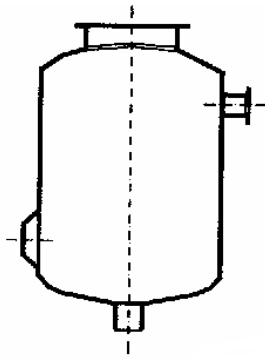

Right

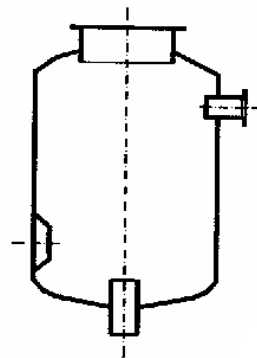

Wrong

The stiffening of the large surfaces, the pore-free continuous welding

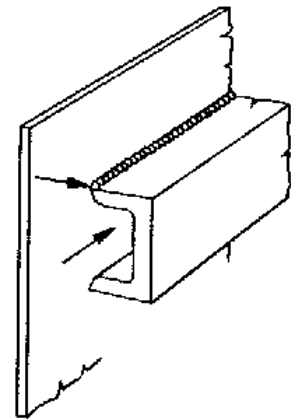
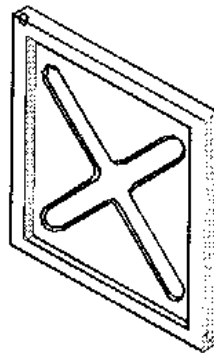
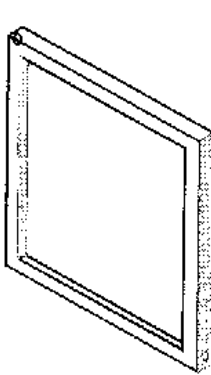

The traces of paint, vaseline or of other organic matters that make the parts preparation difficult and enhance the costs should be preferably avoided !

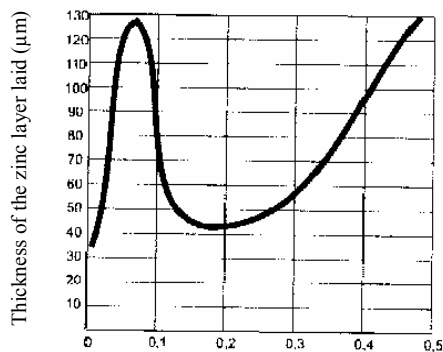

The influence of the silicon content of the galvanized semi-products on the thickness of the zinc layer laid.
The silicon dramatically influences the final look of the galvanization.